

Features

- 2 x high power, high voltage, thick film surge protection resistors
- 2 x high accuracy, high stability matched battery feed resistors
- 2 replaceable 2AG fuses in surface-mounted fuse clips
- Used with the MH89626C for a complete OPS line interface

Applications

- Battery feed and secondary protection for Off-Premise SLICS

ISSUE 2

April 1995

Ordering Information

MH80626C 20 Pin SIL Package

0°C to 70°C

Description

The MH80626C hybrid SIP provides a protection circuit consisting of two 2AG size fuses in surface-mounted fuse clips and two high voltage, high power 5.5Ω surge resistors.

The MH80626C also provides two high stability, high power 50Ω feed resistor matched to 0.1%.

The SIP provides full secondary protection for the MH89626C Off-Premise SLIC, allowing conformance to the requirements of various international safety and performance standards.

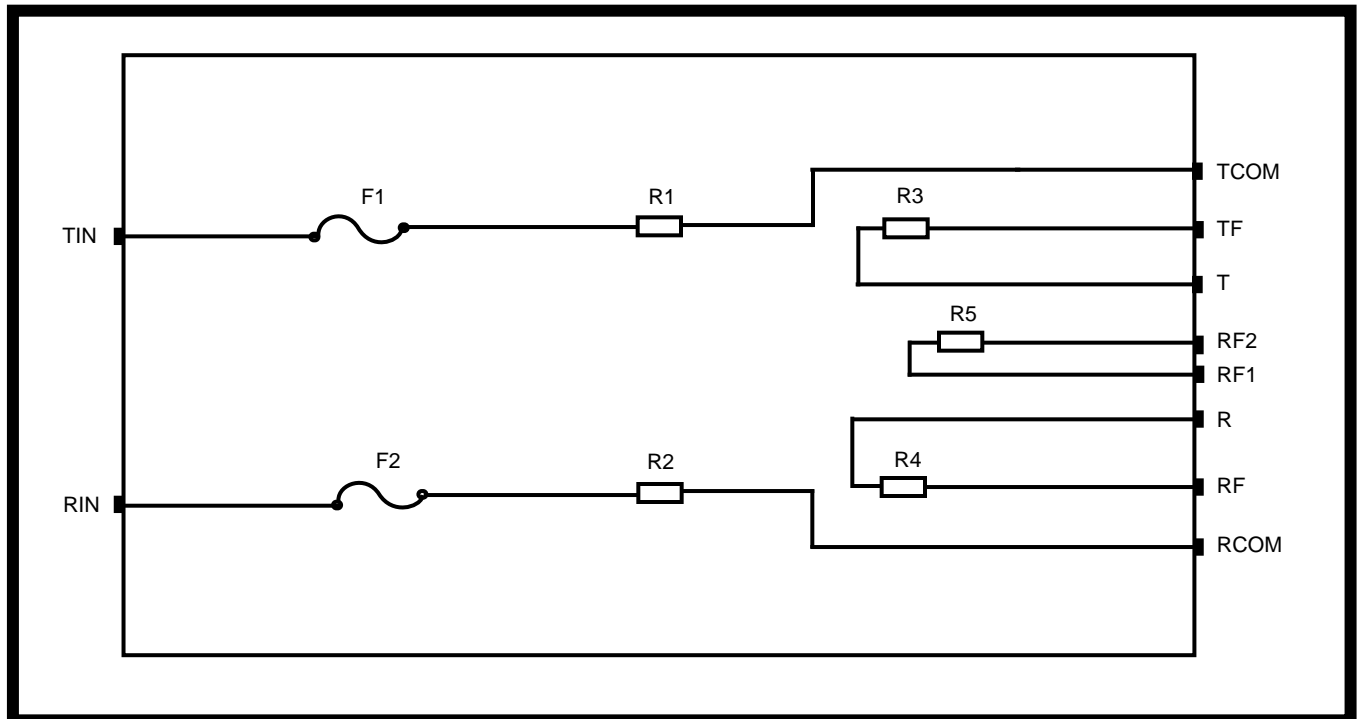

Figure 1 - Functional Block Diagram

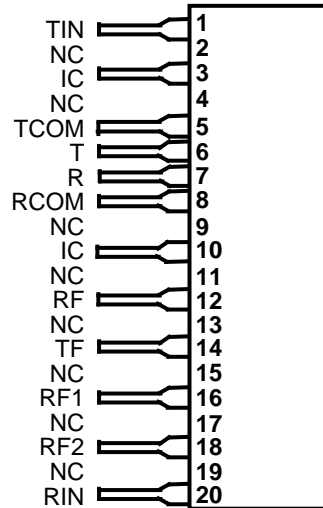

Figure 2 - Pin Connections

Pin Description

Pin #	Name	Description
1	TIN	TIP Input. Connects to TIP conductor of the Subscriber Loop.
2	NC	No Connection: There is no pin in this location
3	IC	Internal Connection: Do no connect to this pin.
4	NC	No Connection: There is no pin in this location.
5	TCOM	TIP Common: Connects to TIP pin of the SLIC via a normally closed ringing relay. See Figure 1.
6	T	TIP Connection: Connects to TIP pin of the SLIC.
7	R	RING Connection: Connect to the RING pin of the SLIC.
8	RCOM	RING Common: Connects to RING pin of the SLIC via a normally closed ringing relay. See Figure 1.
9	NC	No Connection: There is no pin in this location.
10	IC	Internal Connection: Do not connect to this pin.
11	NC	No Connection: There is no pin in this location.
12	RF	RING Feed Connection: Connects to the RF pin of the SLIC.
13	NC	No Connection: There is no pin in this location.
14	TF	TIP Feed Connection: Connect to the TF pin of the SLIC.
15	NC	No Connection: There is no pin in this location.
16	RF1	RING Feed 1. Ringing Input: Connects to ringing supply.
17	NC	No Connection: There is no pin in this location.
18	RF2	RING Feed 2. Ringing Output: Connects to RING line through the ring relay contact.
19	NC	No Connection: There is no pin in this location.
20	RIN	RING Input: Connects to RING conductor of the subscriber loop.

Electrical Characteristics 0°C to 70°C

	Characteristics	Symbol	Min	Typ*	Max	Units	Test Conditions
1	Resistance - absolute	R1	4.5	5.5	6	Ω	
2	Resistance - absolute	R2	4.5	5.5	6	Ω	
3	Resistance - match				1	%	Match between R1 & R2
4	Resistance - absolute	R3	49.75	50	50.25	Ω	
5	Resistance - absolute	R4	49.75	50	50.25	Ω	
6	Resistance - match				0.1	%	Match between R3 & R4
7	Resistance - absolute	R5	555	560	565	Ω	
8	Fuse	F1		0.25		Amps	250 VAC Slow Blow
9	Fuse	F2		0.25		Amps	250 VAC Slow Blow

* Typical figures are at 25°C and are for design aid only

	Reference Specification	Test	Description	Performance	Comments
1	CCITT K.20	Lightning Surge Simulation	1kV 10 x 700 μsec	No damage No arching, fuse intact	See Note 1
2	CCITT K.20	Power Induction	300 Vrms 200 msec	No damage No arching, fuse intact	See Note 1
3	CCITT K.20	Power Cross	220 Vrms 15 min	No damage No arching, fuse blows	See Note 1

Note 1: Refer to the appropriate Telecom Equipment Safety specifications for full details of the test and requirements

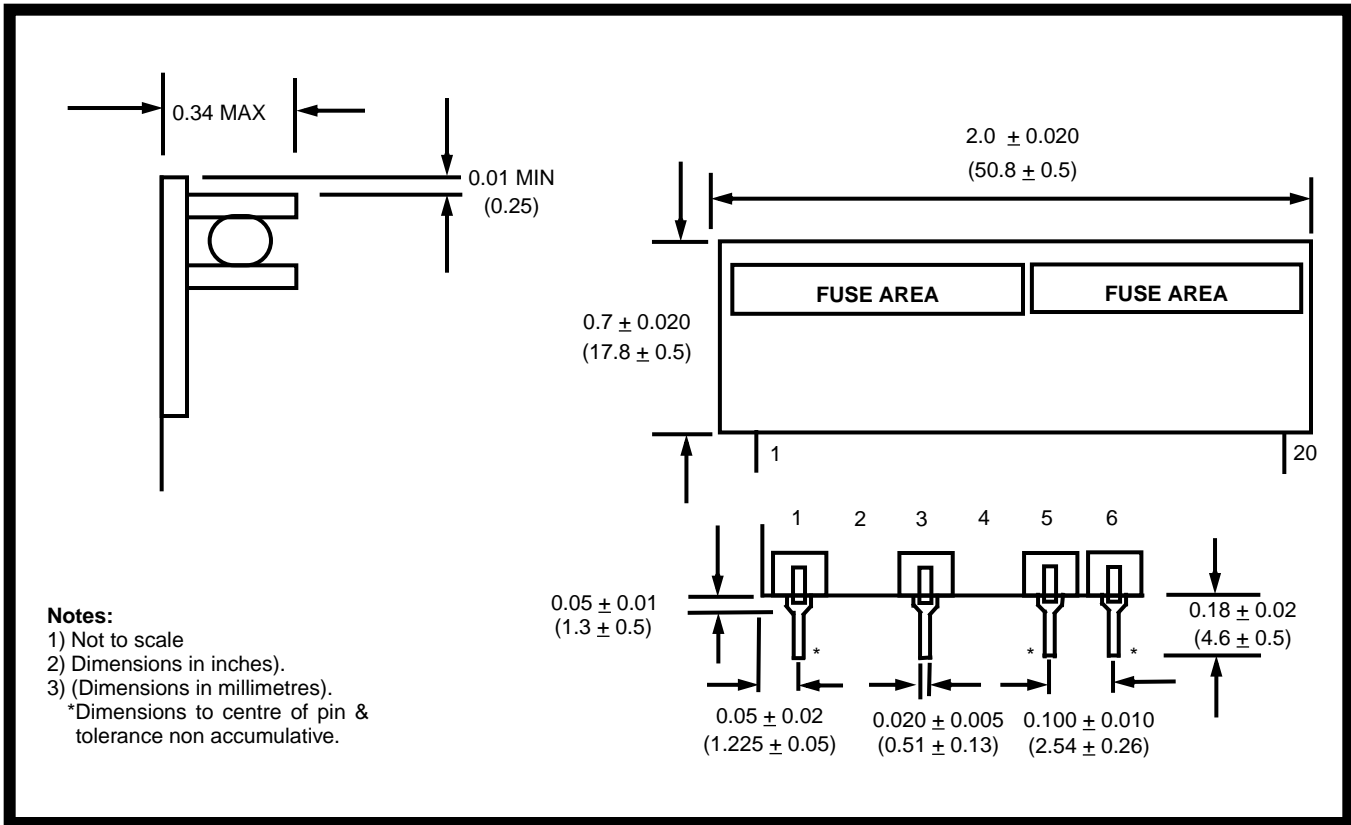

Figure 3 - Mechanical Data